



Intelligent Power Stabilizer

**Modes: IPS-12v-4a
IPS-12v-8a**

The Intelligent Power Stabilizer, IPS, is an electronic power converter for critical electrical equipment found in general aviation aircraft. IPS provides aircraft bus voltage surge and sag protection for the connected electrical equipment. The IPS system will operate over an input voltage range from 5 volts to 15 volts and provides a regulated output voltage of greater than 11.25 volts. The IPS system allows electronic equipment such as engine monitors, EFIS and GPS's to be operational before and during engine starting. This important feature allows the pilot to load flight plan data into the aircraft GPS prior to starting the engine, thereby saving fuel and operating expense. When used with aircraft engine monitors it ensures the pilot can monitor critical engine operating parameters such as oil pressure during the engine starting process.

The electronic power converter in the IPS system ensures the connected electronic equipment is provided with a stabilized source of power even when the aircraft battery voltage drops significantly. This is particularly important during engine starting or alternator out conditions. IPS additionally provides surge protection by actively clamping the regulated output voltage.

The IPS-12v-4a model features a panel mounted low voltage warning light which may be used to provide a pilot warning when the aircraft bus voltage falls below 12 volts.

The Intelligent Power Stabilizer system is suitable for use with equipment such as Garmin GNS-430/w, GNS-530/w, G900X, G3X systems. Advanced Flight System EFIS, Dynon EFIS, Grand Rapids EFIS, MGL EFIS, Tru-trak Autopilots.

No other uses of the IPS system are permitted except for those identified in this installation manual.

IPS must be installed using the current aircraft standards and practices. Refer to AC 43.13-2A/1B. The installer/builder is solely responsible for determining the suitability of the installation and use of this product.

Installation instructions:

1. IMPORTANT NOTE:

Consult the attached wiring diagrams to identify wiring connections similar to your particular installation. Please note, some equipment such as GPS's and EFIS systems may be provided with multiple power inputs. For these installations the IPS system must be connected on the "back-up" power input. It is strongly recommended that the "main" power input in these installations be provided from the aircraft avionics bus. The "back-up" power source should be provided through the IPS system and fed from a bus that is active during engine starting. This will typically be the master bus. For equipment having a single source of power, ensure the IPS system is fed from a bus that remains active during engine starting, such as the master bus.

Garmin 430/530(w) GPS systems are available in versions with and without back-up power inputs. Consult the Garmin GPS installation manual to determine which model you are working with, wiring diagrams for connection of each type to the IPS system are shown at the end of this document.

2. Check the total connected load to be used with the IPS system and ensure that it is less than the following product ratings.

IPS-12v-4a = 4 amps maximum continuous current

IPS-12v-8a = 8 amps maximum continuous current

3. Mount the IPS power converter in a suitable location in the aircraft. The IPS must be mounted inside the aircraft, do not mount IPS in the firewall forward area.

4. For the IPS-12v-4a, mount the Low Voltage warning light on the instrument panel in the pilot's viewing area. **The LV warning light is polarized, observe polarity: + to white/red stripe, - to white/black stripe.**

5. Connect the aircraft wiring according to the wiring diagrams as shown.

IPS must be powered through a properly sized circuit breaker or fuse. ENSURE the proper size wire is utilized for the input feed and ground connection powering the IPS system. Additionally, the output of the IPS must be fused as shown in the wiring diagrams.

IPS-12v-4a model: Input Fuse = 12 amps, Output Fuse= 5 amps

IPS-12v-8a model: Input Fuse = 25 amps, Output Fuse= 10 amps

PRODUCT OPERATION:

The IPS system is fully automatic and requires no input from the pilot. The IPS system will provide a regulated output voltage to the connected equipment with an input bus voltage as low as 5 volts. The IPS system will automatic shut down if the input bus voltage remains below 4 volts for an extended period of time. NOTE: During automatic shutdown the output voltage of the IPS will no longer be regulated, but instead will fall to the nominal input voltage, thereby reverting back to system operation equivalent to that of systems not having the benefits of the IPS system.

IMPORTANT NOTES:

If the aircraft battery is extremely weak, the IPS system may not be able to keep the connected equipment operational during engine starting. If the battery is incapable of driving the starter to rotate the engine through a complete compression cycle the aircraft battery may be sagging below 4 volts. During these conditions the IPS system will protect itself and the attached equipment by shutting down.

Battery replacement is strongly encouraged if this condition exists.

Additionally, if the aircraft battery is deeply discharged, i.e. below 9 volts continuous output with no load attached, then when the aircraft systems are initially energized (i.e. at aircraft power-up) the IPS system will not boost the output voltage and it is likely the attached equipment will not power up. This is a warning the aircraft battery is in a state of deep discharge and may be in need of service or replacement.

TCW Technologies, LLC.
2955 Main Road East
Emmaus, PA 18049

610-928-3420

www.tcwtech.com

email: support@tcwtech.com

SPECIFICATIONS:

Input Voltage:	5-15 volts DC,
Output Voltage:	>11.25 volts DC
Output Current:	IPS-12v-4a 4 amps continuous IPS-12v-8a 8 amps continuous
Converter:	True DC:DC converter with output over voltage, over current and over temperature protection
Panel warning light:	IPS-12v-4a only model, preset to 12.0 volts
Surge Protection:	16 volt active clamp, 1500w 10/1000uS waveform
Wiring:	IPS-12v-8a : insulated barrier strip, #6 screws IPS-12v-4a : 4ft leads, Mil-spec wire
Enclosure:	Cast aluminum IPS-12v-8a : 4.6" x 3.7" x 1.18" IPS-12v-4a : 4.39" x 2.34" x 1.06"
Weight:	IPS-12v-8a : 14 oz. IPS-12v-4a : 8 oz.
Temperature range:	-25 C to 60 C

Intelligent Power Stabilizer™

Wiring Diagram IPS-12v-4a

Equipment without Back-up Power Input

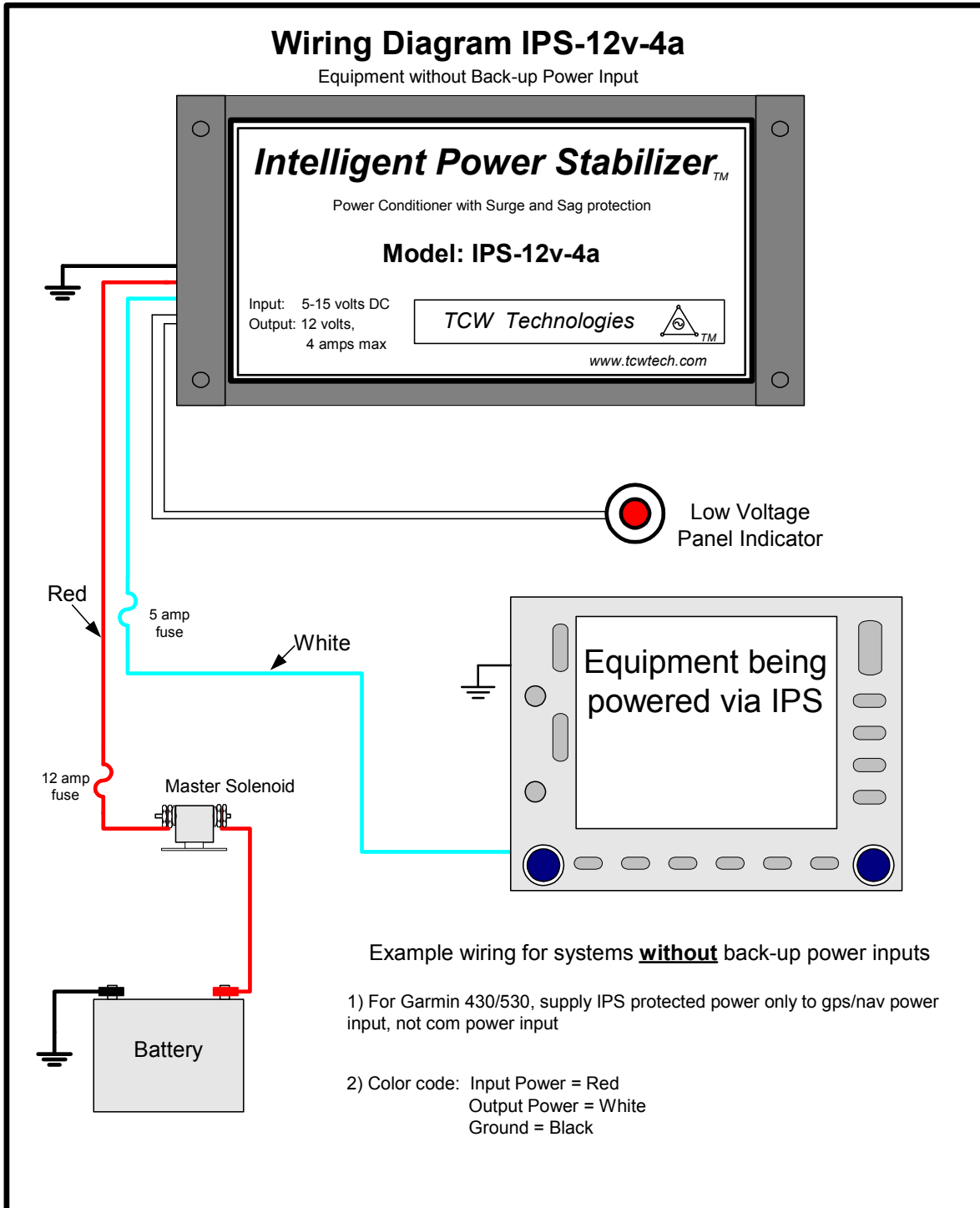

Intelligent Power Stabilizer™

Wiring Diagram IPS-12v-4a

Equipment with Back-up Power Input

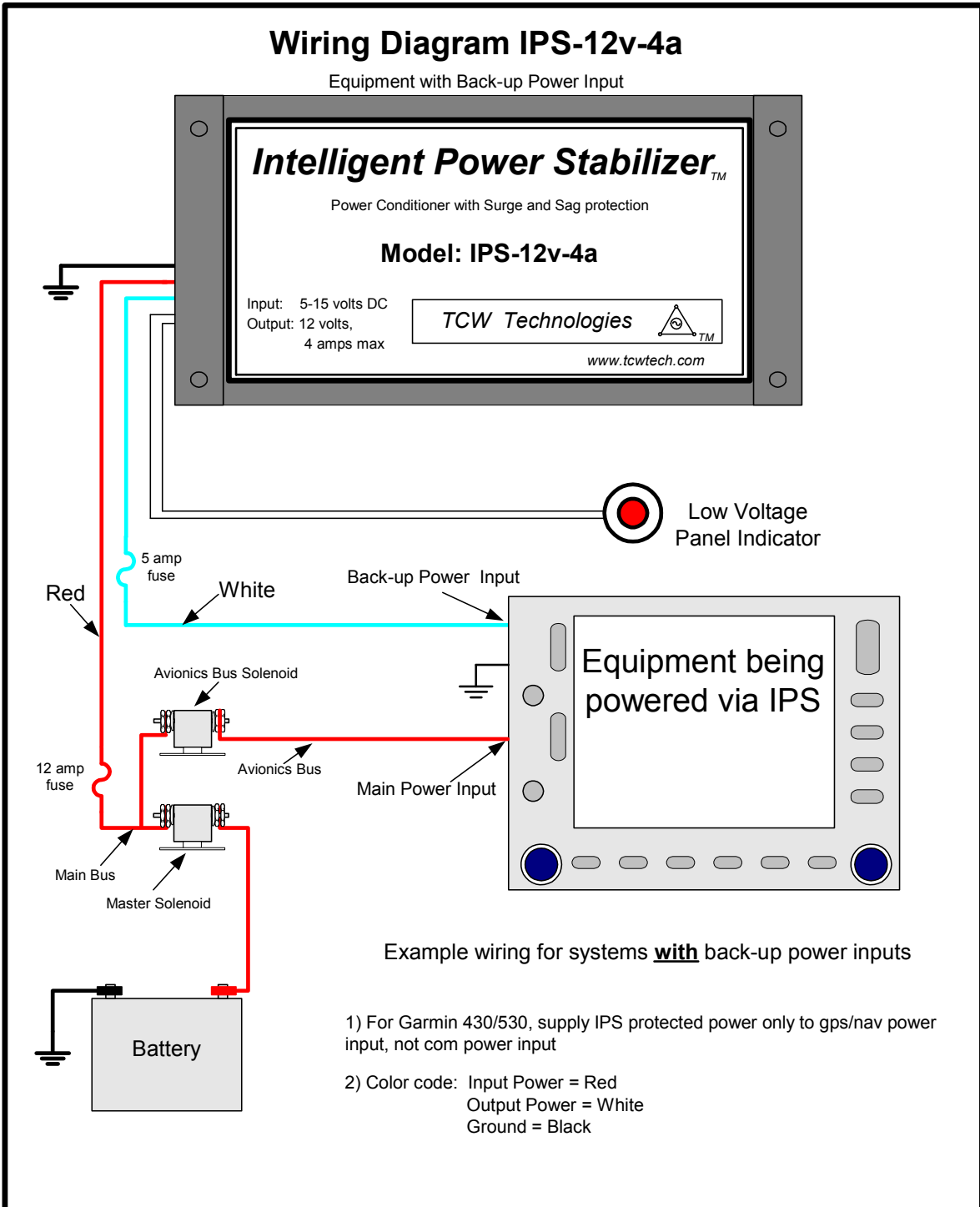

Intelligent Power Stabilizer™

Power Conditioner with Surge and Sag protection

Model: IPS-12v-4a

Input: 5-15 volts DC
Output: 12 volts,
4 amps max

TCW Technologies



www.tcwtech.com

Equipment being
powered via IPS

Example wiring for systems with back-up power inputs

- 1) For Garmin 430/530, supply IPS protected power only to gps/nav power input, not com power input
- 2) Color code: Input Power = Red
Output Power = White
Ground = Black

Intelligent Power Stabilizer™

Wiring Diagram IPS-12v-8a

Equipment without Back-up Power Input

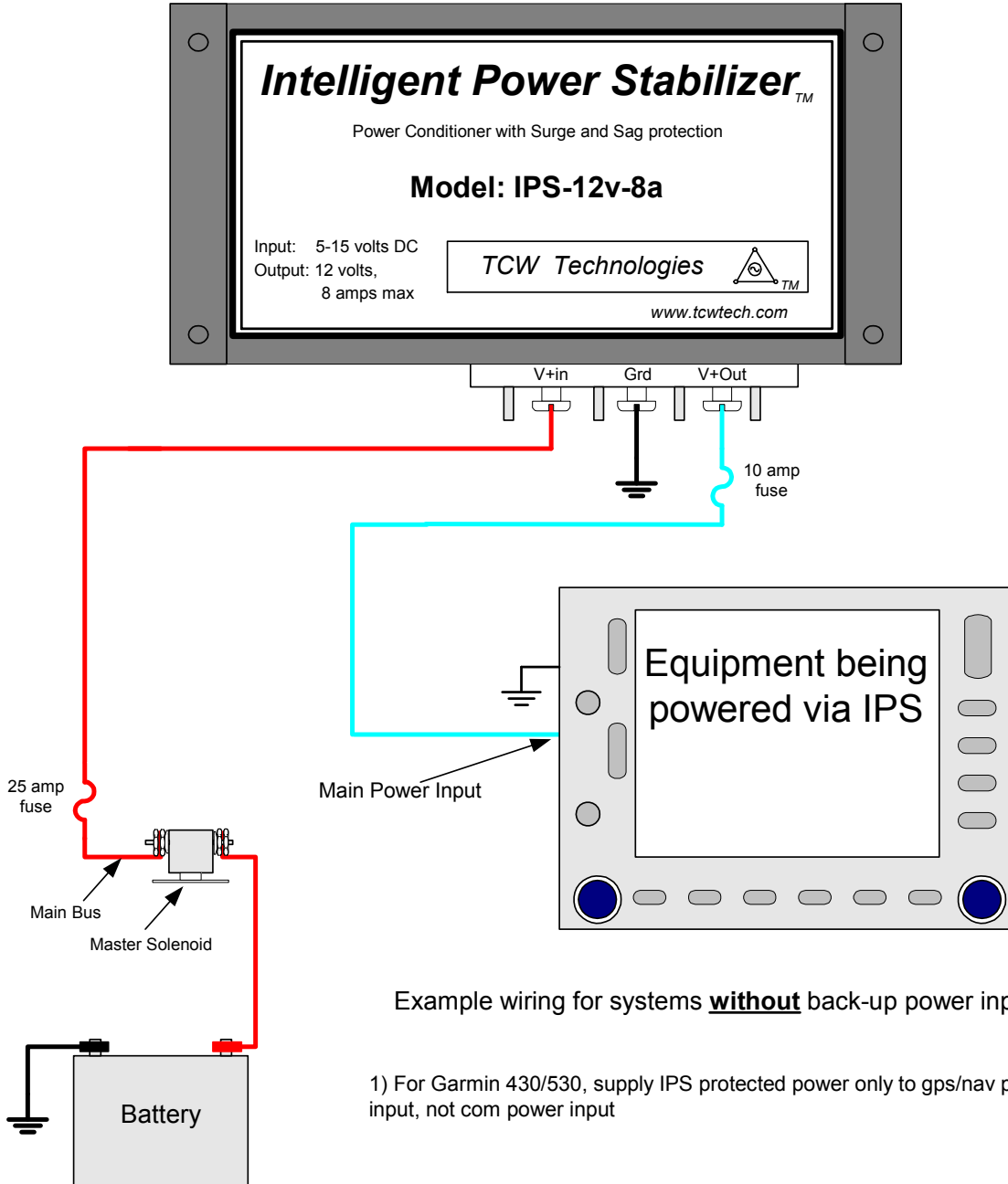

Example wiring for systems **without** back-up power inputs

1) For Garmin 430/530, supply IPS protected power only to gps/nav power input, not com power input

Intelligent Power Stabilizer™

Wiring Diagram IPS-12v-8a

Equipment with Back-up Power Input

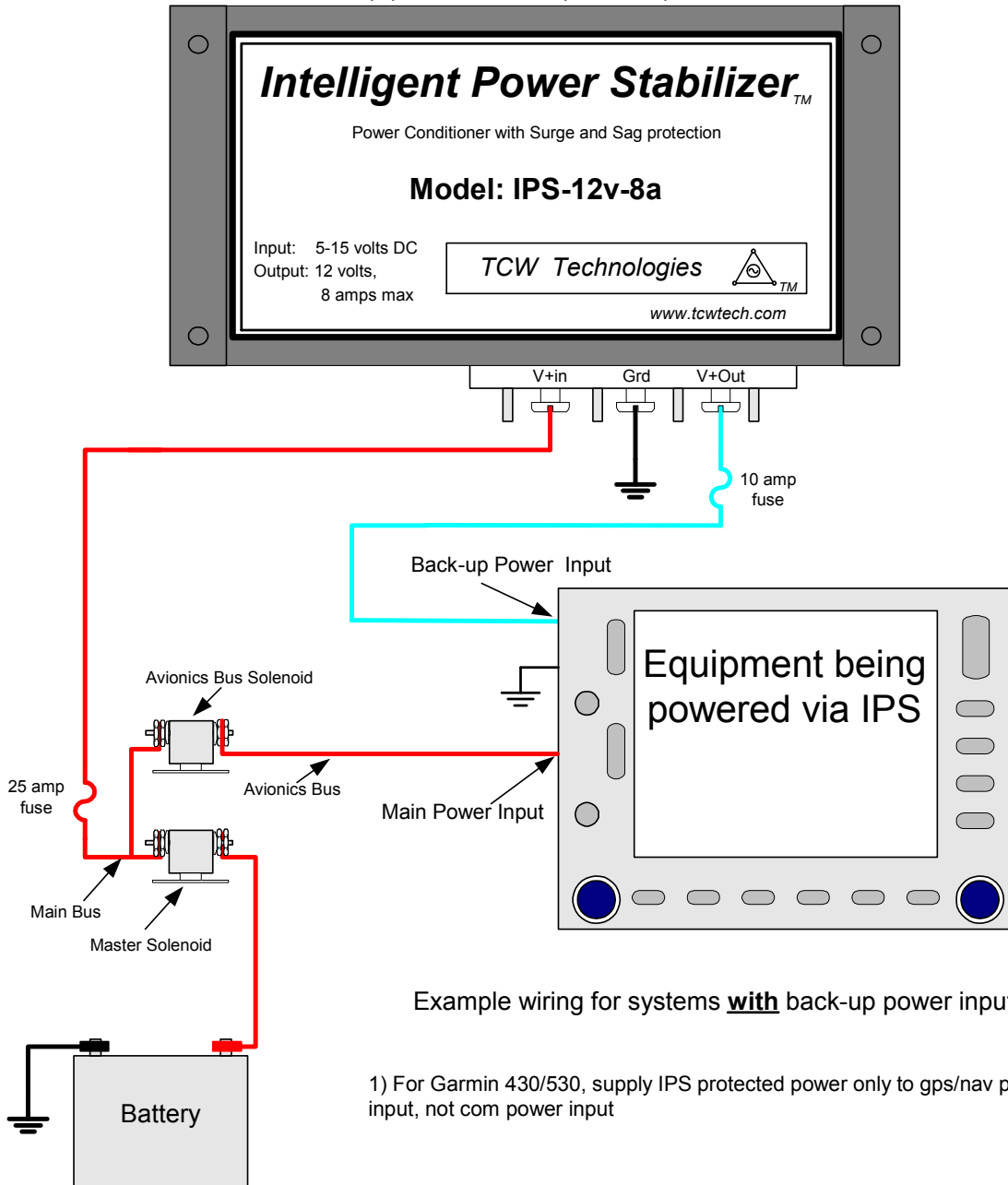

Wiring Diagram for connection of IPS to Garmin 430/530 systems

Intelligent Power Stabilizer™

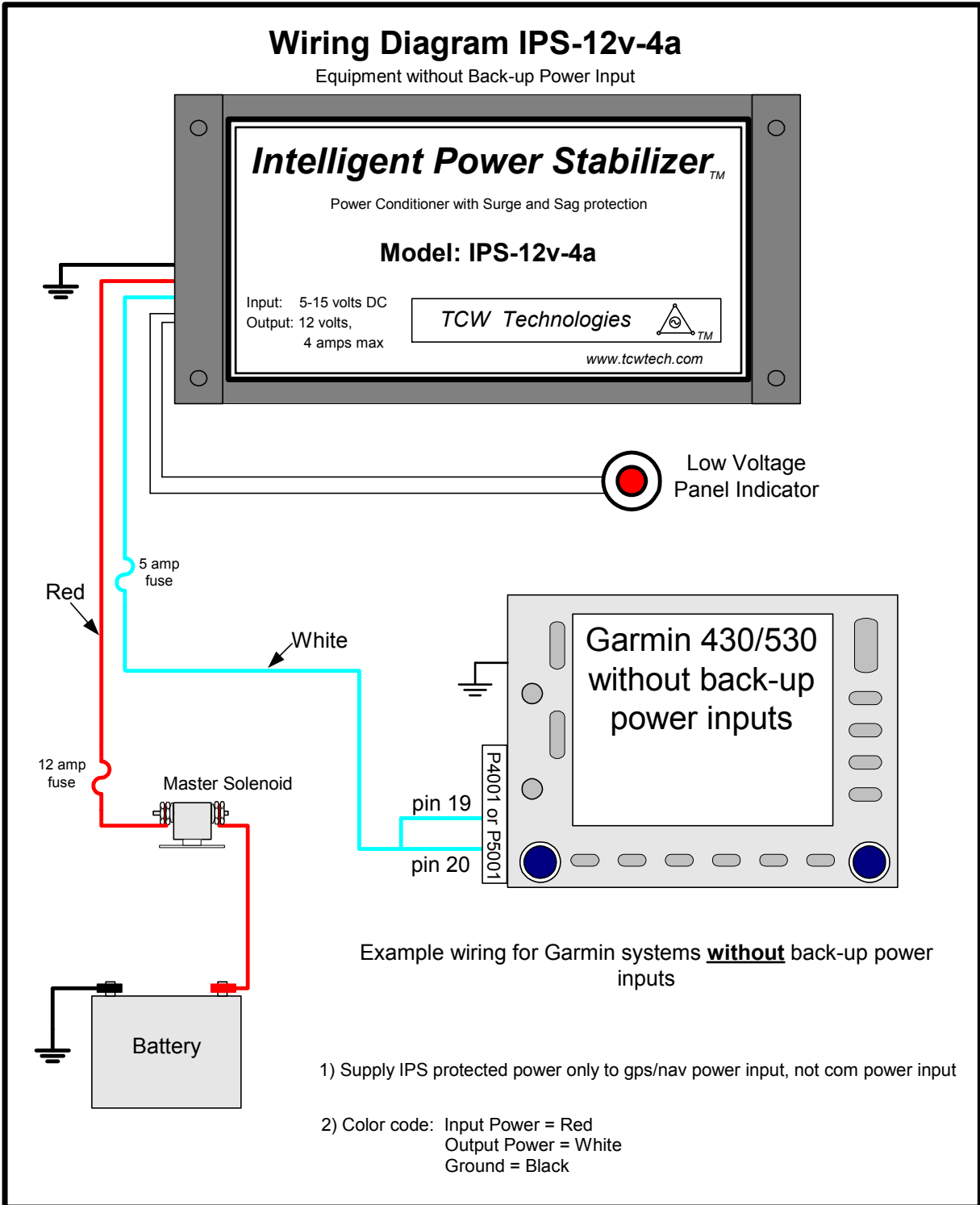

Wiring Diagram for connection of IPS to Garmin 430/530 systems

Intelligent Power Stabilizer™

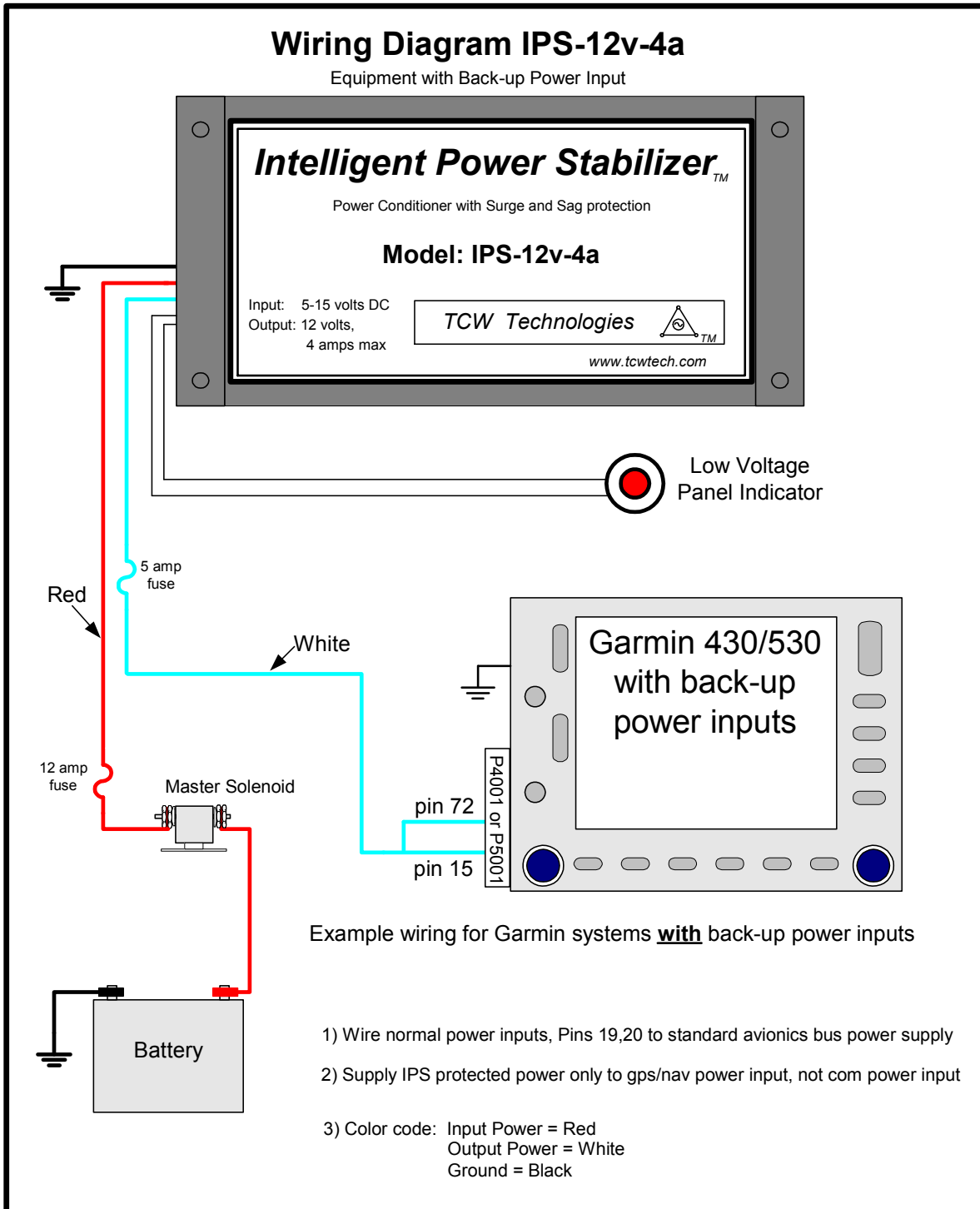

Intelligent Power Stabilizer™

Wiring Diagram IPS-12v-8a used with Garmin G900x Avionics

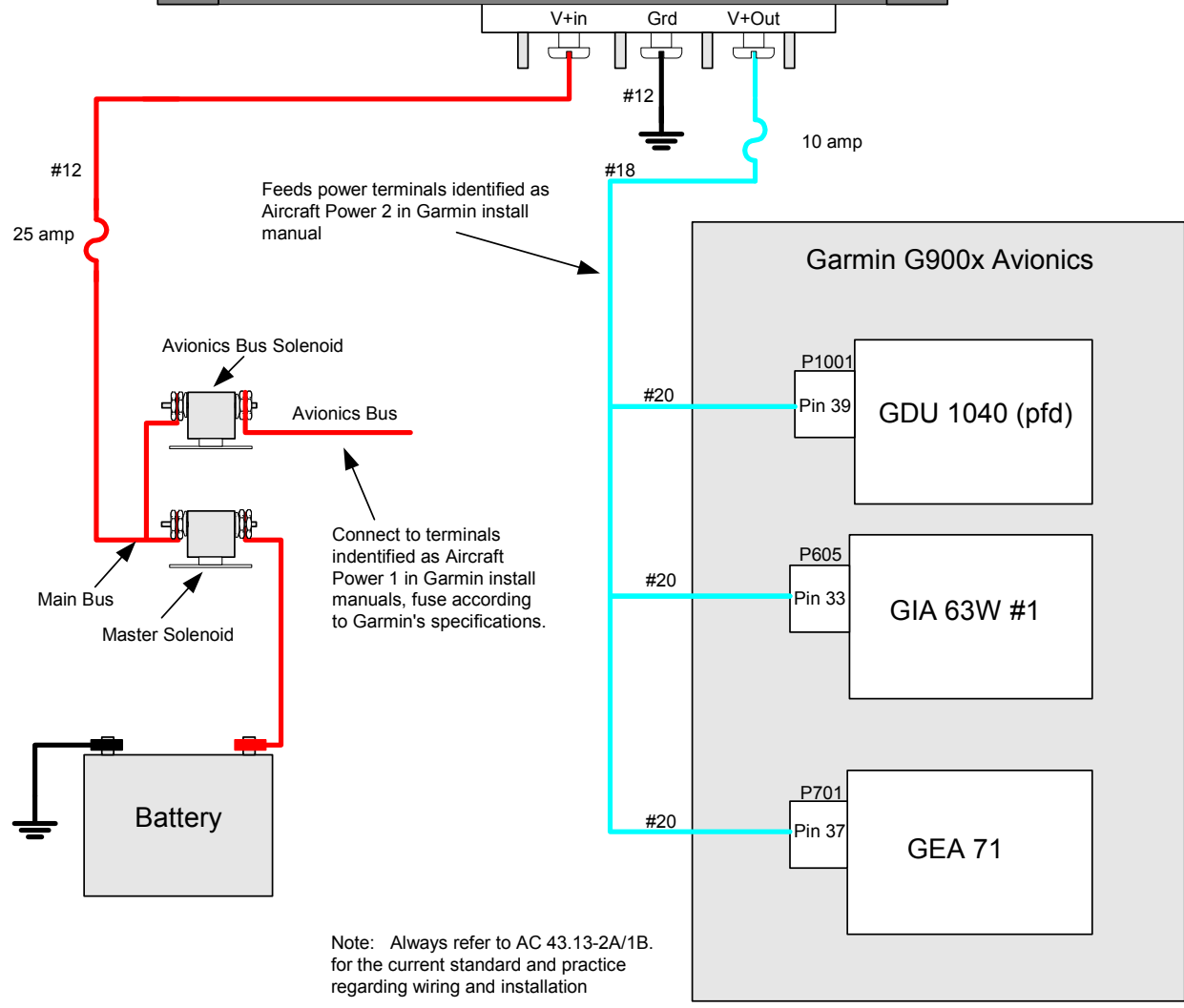
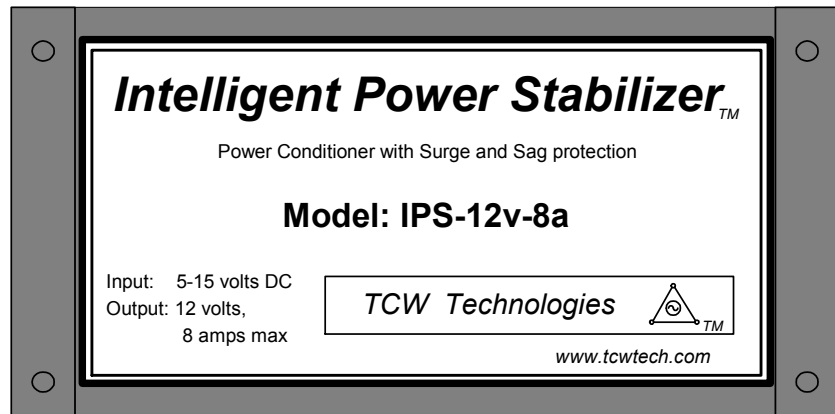

Note: Always refer to AC 43.13-2A/1B. for the current standard and practice regarding wiring and installation

Intelligent Power Stabilizer™

Wiring Diagram IPS-12v-4a

IPS used with Garmin G3x system

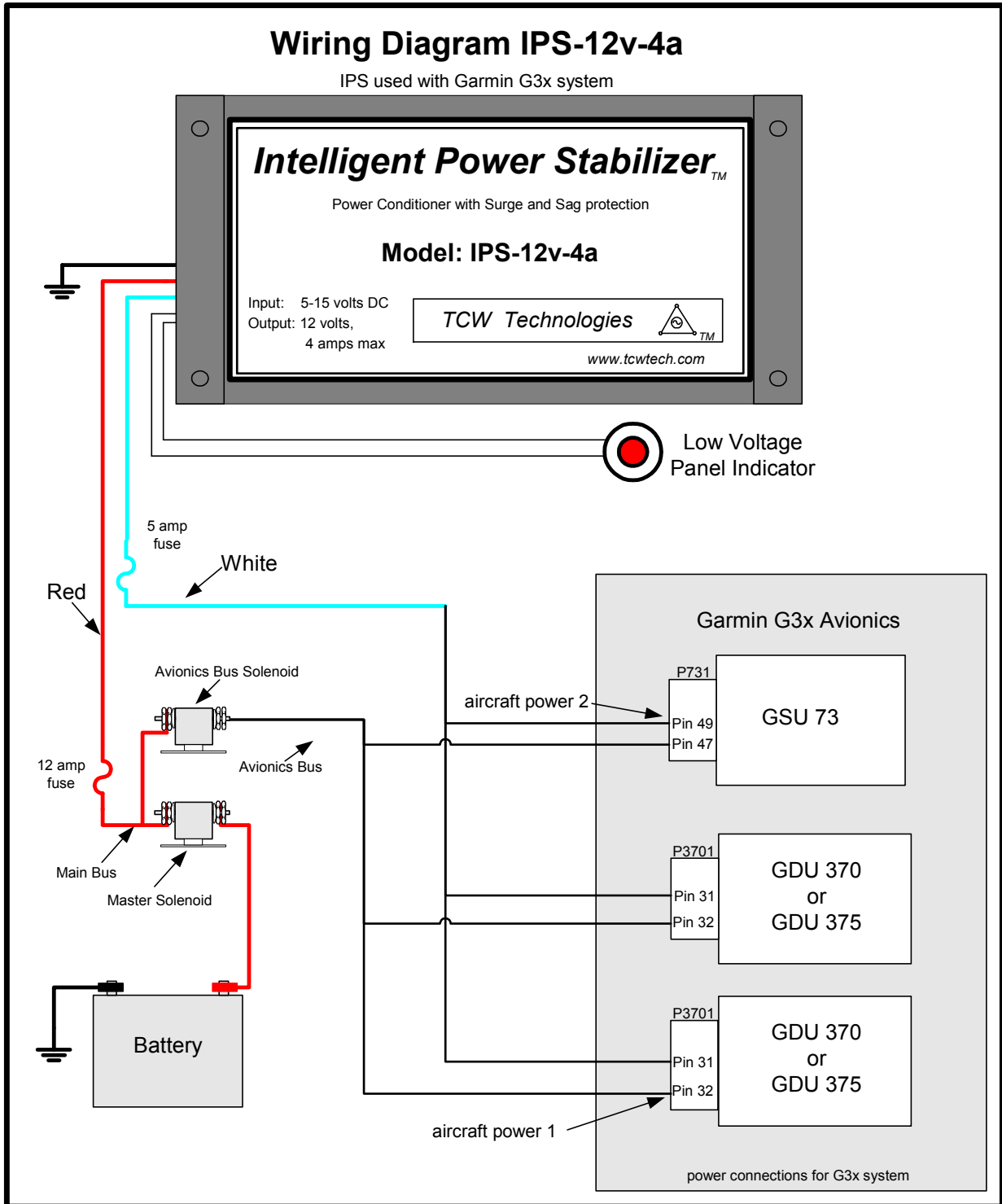

TCW Technologies, LLC.

During the first 24 months from the date of purchase and subject to the conditions hereinafter set forth, TCW Technologies, LLC. (TCW) will repair or replace to the original user or consumer any portion of your new product which proves defective due to defective materials or workmanship of TCW. Contact TCW Technologies for warranty service. TCW shall have and possess the sole right and option to determine whether to repair or replace defective equipment, parts or components. Damage due to equipment, environment or conditions beyond the control of TCW Technologies are NOT COVERED BY THIS WARRANTY.

LABOR, COSTS: TCW shall IN NO EVENT be responsible or liable for the cost of field labor or other charges incurred by any customer in removing and/or reaffixing any TCW product, part or component thereof.

THIS WARRANTY WILL NOT APPLY: (a) to defects or malfunctions resulting from failure to properly install, operate or maintain the unit in accordance with printed instructions provided; (b) to failures resulting from abuse, accident, or negligence; (c) to normal maintenance services and the parts used in connection with such service; (d) to units which are not installed in accordance good trade practices; or (e) to unit used for purposes other than for what it was designed and manufactured.

RETURN OR REPLACED COMPONENTS: any item to be replaced under this Warranty must be returned to TCW Technologies in Emmaus, PA, or such place as TCW may designate, freight prepaid.

PRODUCT IMPROVEMENTS: TCW reserves the right to change or improve its products or any portions thereof without being obligated to provide such a change or improvement for units sold and /or shipped prior to such change or improvement.

WARRANTY EXCLUSIONS: as to any specific TCW product, after the expiration of the time period of the warranty applicable thereto as set forth above. THERE WILL BE NO WARRANTIES, INCLUDING ANY IMPLIED WARRANTIES OR MERCHANTABILITY OR FITNESS FOR ANY PARTICULAR PURPOSE.

Some states do not allow limitations on how long an implied warranty lasts, so the above limitation may not apply to you. No warranties or representations at any time made by any representative of TCW shall vary or expand the provisions hereof.

LIABILITY LIMITATION: IN NO EVENT SHALL TCW OR ITS AFFILIATES BE LIABLE OR RESPONSIBLE FOR CONSEQUENTIAL, INCIDENTAL OR SPECIAL DAMAGES RESULTING FROM OR RELATED IN ANY MANNER TO ANY TCW PRODUCT OR PARTS THEREOF. THE SUITABILITY OF USE OF THE INTELLIGENT POWER STABILIZER PRODUCT IS TO BE DETERMINED BY THE AIRCRAFT HOMEOWNER.

Some states do not allow the exclusion or limitation of incidental or consequential damages, so the above limitation or exclusion may not apply to you.

This Warranty gives you specific legal rights and you may also have other rights which vary from state to state. In the absence of other suitable proof of this installation date, the effective date of this Warranty will be based upon the date of manufacture plus one year. Direct All Notices To: Warranty and Product Service Department, TCW Technologies, 4906 Raymond Ct. Emmaus, PA 18049